

**SWPPP Information**

**Nature of Construction Activity**  
Street, drainage, and utility improvements for residential subdivision development. Potential pollutants and sources - Sediment from excavations and equipment movements around the site.

- Schedule of Events**
1. Install silt fencing.
  2. Install stabilized construction exit.
  3. Clear and grub.
  4. Rough grading.
  5. Install utilities.
  6. Construct roadways.
  7. Complete grading and install permanent seeding.
  8. When all construction activity is completed and the site is stabilized, remove silt fence and re-seed any areas disturbed during construction and assure a healthy ground cover.

**Areas of Disturbance**  
During the construction of pavement, drainage, and utility improvements the entire lot will be disturbed.

**Structural Controls**  
Temporary stabilization ~ areas where construction activity temporarily ceases for at least 21 days will be stabilized with temporary seed no later than 14 days from the last construction activity in that area. All proposed fill material will be seeded.

Silt fence and/or hay bales will be installed at all outfalls, areas where water runs off the site; inlets under construction will have silt fencing or hay bales placed around the perimeter of the inlet all constructed inlets will have sandbags placed in front of the throat to collect sediment but allow flow of water into the inlet.

**Storm Water Management**  
Storm water drainage will be controlled by existing grass-lined drainage ditches. All areas affected by construction will be fine graded and have permanent seeding. The remainder of the area will remain in its natural state.

**Offsite Vehicle Tracking**  
A stabilized construction exit(s) will be established as shown on the plan to help reduce vehicle tracking of sediments. The paved street adjacent to the site exit will be swept to remove any excess mud, dirt, or rock tracked from the site. Dump trucks hauling material from the construction site will be covered with a tarpulin.

**Certification of Compliance with State and Local Regulations**  
This stormwater pollution prevention plan reflects the city's/state's requirements for storm water management, erosion, and sediment control. To ensure compliance, this plan was prepared in accordance with the city's drainage policy.

**NOI & NOT INFORMATION:**  
The site is approximately 0.11 acres and is located along Villa Maria Road (FM 1179) on the Brazos Christian School Site in Bryan, Texas. The site is located at North Latitude 30°36'54" and West Longitude 96°24'10". The site activity will consist of the construction of buildings and parking for an expansion to the existing school facilities. The only source of pollution is the erosion of exposed soil. Storm water from the site flow into Turkey Creek. The Contractor is responsible for containing all sediment on-site by utilizing siltation control devices, washdown areas, or seeding and sodding applications. It is the responsibility of the Contractor to utilize whatever techniques that are necessary to prevent erosion from this construction.

- GENERAL EROSION CONTROL NOTES:**
1. It is the responsibility of the Contractor to prepare and maintain a Storm Water Pollution Prevention Plan in accordance with the Bryan/College Station Unified Stormwater Design Guidelines and EPA requirements for storm water discharges associated with construction activity under General Permit, USACE 33 CFR, & Section 404 of the Clean Water Act, & Texas Pollutant Discharge Elimination System (TPDES) General Permit No. TXR150000 as administered by the Texas Commission on Environmental Quality (TCEQ).
  2. The Contractor shall not allow sediment to leave the work area or enter any adjoining channels. Additional measures to those shown on this plan and described in these notes may be required to prevent sediment from leaving the work area. The contractor shall be responsible for clean-up and restoration to original condition, including establishment or re-vegetation of any lands or channels affected should construction sediment be found outside of limits of construction work.
  3. All disturbed areas are to have establishment of grass as outlined below. Contractor is responsible for watering, maintenance and establishment of grass for a period of 90 days beyond project acceptance. Contractor to guarantee all planted material growth and coverage for a period of 6 months. Growth and coverage shall be defined as 100% of the planted area with uniform coverage of grass greater than 1" in height with no bare spots greater than 2 square feet. A second application of fibermulch is required for bare spots not meeting coverage requirement within 60 days of initial application. Areas adjacent to the building and within the development to receive block sodding and/or landscaping are not included in this requirement.
  4. Contractor is to maintain erosion control throughout duration of the project such that all work areas are to plan grades once vegetation is established. Insite sediment is not transported downstream from project via hay bales or silt fence installation. If erosion is observed in the field, additional erosion controls shall be installed.
  5. Silt fencing is to be installed per detail. In lieu of silt fencing, contractor may use straw bale barriers or continuous extruded fabric berm filled with 3/4" gravel upon approval of the engineer. Sediment to be cleaned from silt fencing or other sediment control devices when depth of sediment reaches ±1/3 total height of device. Contractor is to insure erosion control devices are consistently installed and properly maintained.
- GENERAL CONSTRUCTION NOTES:**
1. It shall be the responsibility of the Contractor to verify the exact location of all existing underground utilities. Furthermore, the Contractor shall contact all utility company representatives a minimum of 48 hours in advance of any excavation.
    - A. Contact Texas811 @ 811
    - B. Contact City of Bryan Water Services @ 979-209-5900 to locate public water and sewer lines.
    - C. Contact TxDOT @ 979-772-2165
  2. Construction within Public Right-of-Ways and easements must equal or exceed the BCS Unified Technical Specification and Standard Construction Details. All inspections shall be coordinated with the staff of the City Engineer of Bryan.
  3. In lieu of using the construction materials indicated in these plans, the Contractor shall obtain written approval from the Engineer for any substitution.
  4. Trench Safety Requirements shall be in accordance with O.S.H.A. Standard 29 CFR Part 1926 Subpart P.
  5. **TRENCHING AND BACKFILLING:** The backfilling of all trenches within structural areas shall be accomplished with cement stabilized sand placed to within 6" of paving sub-grade. The backfilling of all trenches outside of structural areas shall be placed so as to achieve 85 percent Modified Proctor Density. All backfilling shall be between optimum and 4 percent (4%) above optimum moisture content. Testing shall be provided by a certified laboratory at the Owner's expense to verify these standards. Any retesting due to substandard work shall be at the expense of the Contractor. Structural areas shall include all sidewalks and paved areas. For streets, alleys and parking areas, the limits of the structural areas shall extend 5' beyond the curb lines or other paved areas.
  6. It is the responsibility of the contractor to comply with all State and Federal Regulations regarding construction activities near energized overhead power lines. Additionally, the contractor shall coordinate all proposed work and procedures with the Bryan Texas Utilities (BTU).
  7. Where a contradiction between plans and specifications occur, the plans shall be ruled as superior.
  8. Trenches may be left open overnight if properly barricaded to prevent pedestrian access.
  9. It shall be the responsibility of the Contractor to prepare and maintain a SWPPP and submit a Small Construction Site Notice and coordinate with City staff. Disturbed Area ~0.1 acres.
  10. Contractor shall adjust all existing manholes and valve boxes to final grades. There will be no separate pay item will be this work.
  11. Refer to Architectural Plans for top of finished light pole foundation elevations.
  12. Construction of the fire line will need to comply with current NFPA 24 standards.
  13. Existing concrete wash-out located near the Sports Performance Center to be utilized for this project.

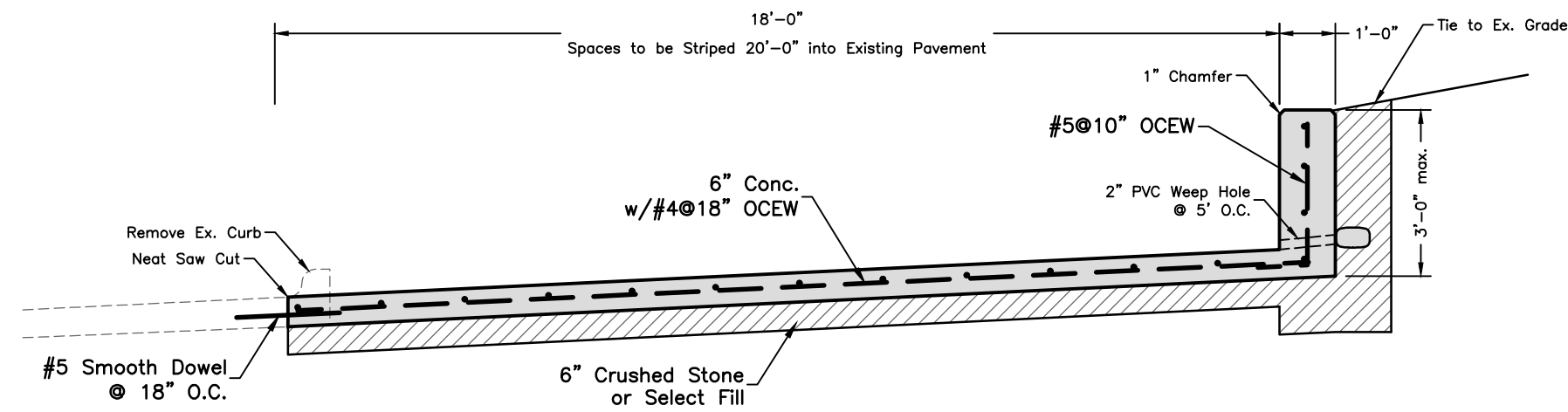

**SECTION A-A**

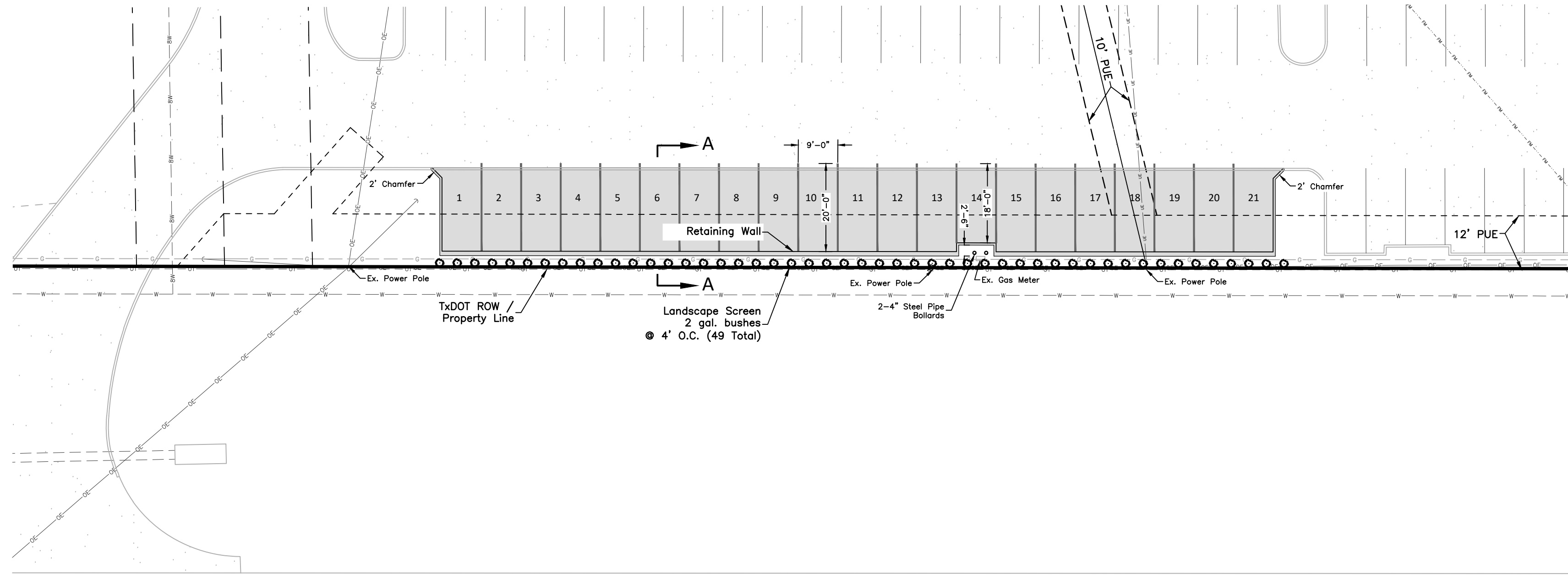

**FM 1179 - W. VILLA MARIA ROAD**

**SITE PLAN**

SCALE: Hor: 1" = 20'

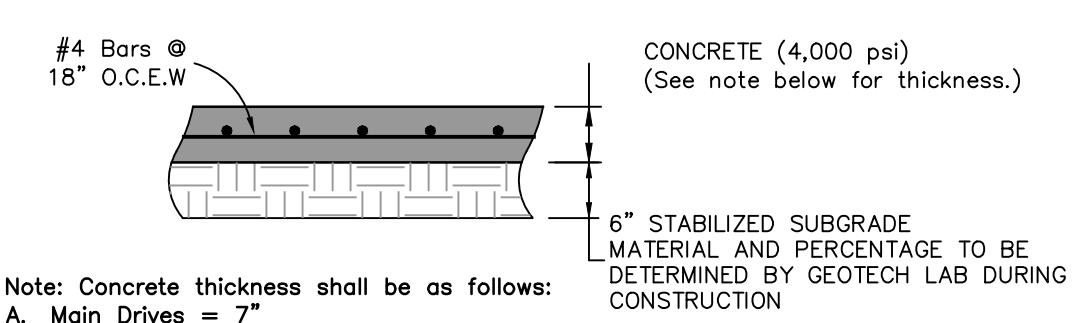

- Note: Concrete thickness shall be as follows:
- A. Main Drives = 7"
  - B. Parking Spaces = 5"
  - C. Sidewalk = 4"
  - D. Pavement sections shall be constructed in accordance with the BCS Unified Technical Specifications.
  - E. Subgrade shall be compacted to 95% of Standard Proctor Density as per ASTM D968 at moisture contents in the range of the optimum moisture content to 4% above the optimum moisture content.

- Legend**
- - 1/2" Iron Rod Set
  - ⊙ - 1/2" Iron Rod Found
  - ⊙ - 5/8" Iron Rod Found
  - s— Existing Sewer Line w/ size
  - w— Existing Water Line w/ size
  - ss— Proposed Sewer Line w/ size
  - ww— Proposed Water Line w/ size
  - cc— Existing Gas Line w/ size
  - oc— Existing Overhead Electric Line
  - ← Guy Anchor
- Abbreviations**
- D.E. Drainage Easement
  - D.D.F.E. Drainage Detention Facility Easement
  - D.R. Brazos County Deed Records
  - E.A.E. Emergency Access Easement
  - F.H. Fire Hydrant
  - O.R. Brazos County Official Records
  - P.A.E. Public Access Easement
  - P.R. Brazos County Plat Records
  - P.R.A. Public Utility Easement
  - R.O.W. Right-of-Way
  - U.E. Utility Easement
  - P.R.A.E. Private Access Easement
  - S.D. Storm Drain
  - P.L.E. Private Landscape Easement
  - F.D.C. Fire Department Connection

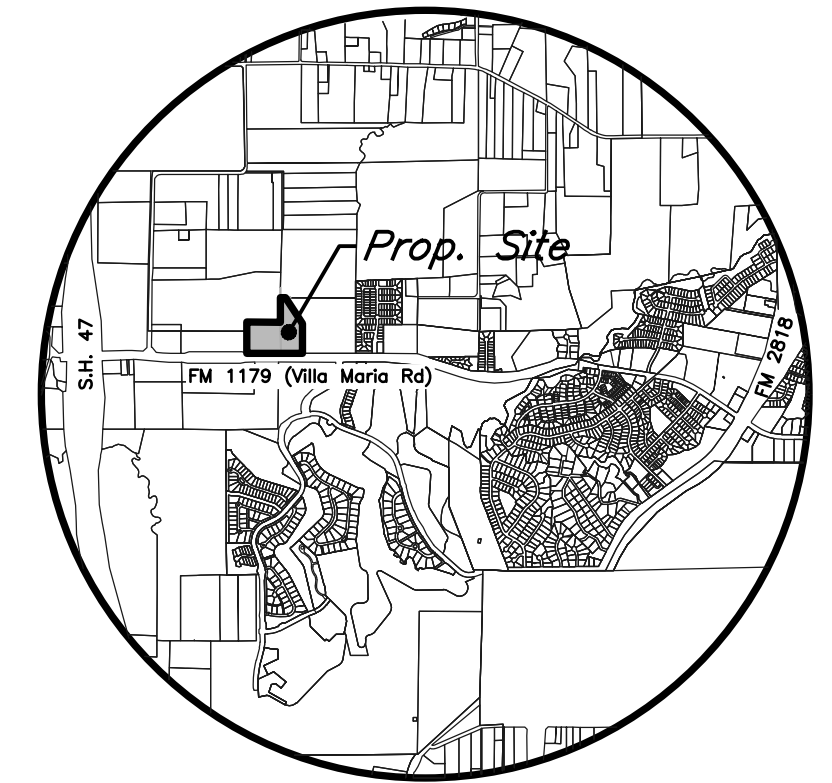

**VICINITY MAP**

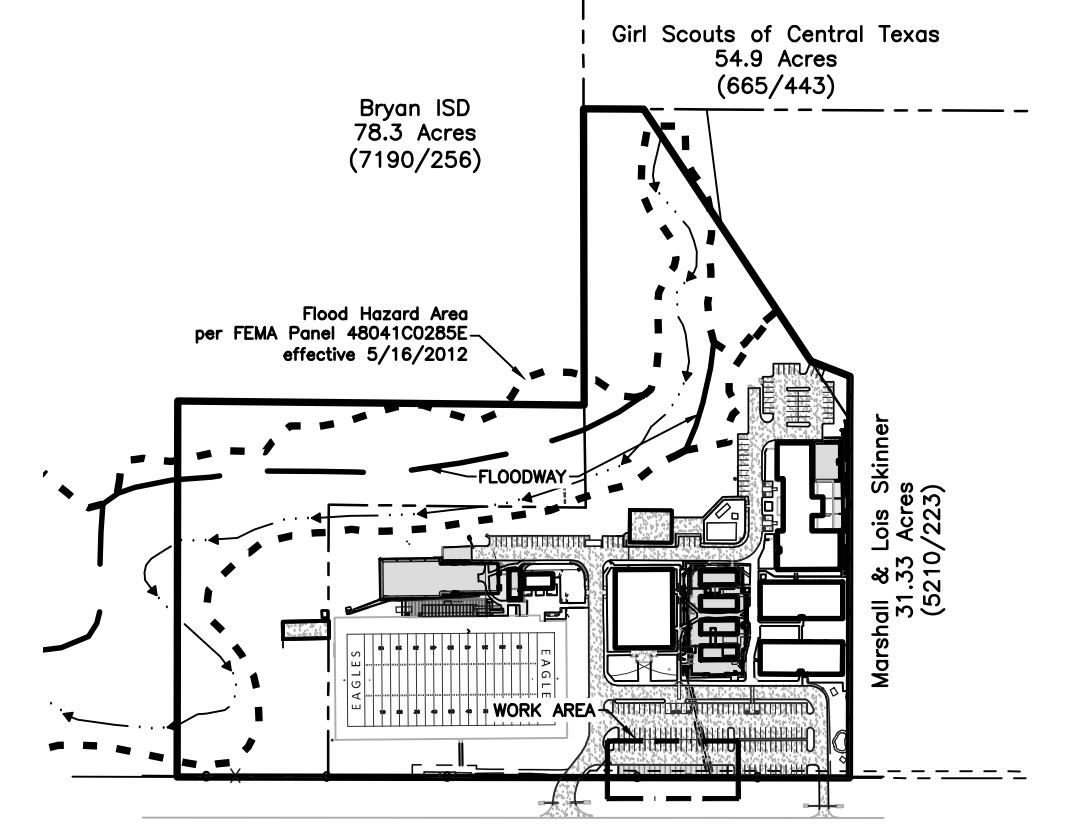

**ADJACENT PROPERTY MAP**

**SITE PLAN NOTES:**

1. This property is zoned Planned Development (PD) per ordinance 1694
2. Owner & Applicant: Brazos Christian School
3. Proposed Use: School
4. The total site area as recorded in deed records is 20.9 acres
5. **BUILDING USAGE DETAILS:**  
No Proposed Buildings with this submittal.
6. **PARKING ANALYSIS:**

School:	1 parking space per 3 High School Students	(200 students / 3) = 67
	1 parking space per 15 Middle School Students	(150 students / 15) = 10
	1 parking space per 20 Elementary School Students	(300 students / 20) = 15
<b>Total Required Parking Spaces:</b>		<b>92 spaces</b>
<b>Parking Spaces Provided:</b>		<b>217 spaces</b>
<b>Total Parking Lot Spaces:</b>		<b>217 spaces</b>
<b>Handicap Spaces Required:</b>		<b>7 spaces</b>
<b>Total Handicap Spaces Provided:</b>		<b>9 spaces</b>
7. **WATER AND SANITARY SEWER DEMANDS:**  
No Proposed Buildings with this submittal.
8. **FIRE FLOW REQUIREMENTS:**  
No Proposed Buildings with this submittal.
9. **BASIS OF BEARINGS:** The bearing system and actual measure distance to the monuments are Grid North, Texas State Plane Coordinate System, Central Zone, NAD83 per GPS Observation.
10. According to the Flood Insurance Rate Maps for Brazos County, Texas and Incorporated Areas, Map Number 48041C0285E, Map Revised May 16, 2012, a portion of this property is located in a Special Flood Hazard Area.
11. Building Setbacks shall comply with the City of Bryan Standards
  - Front Setback = 25'
  - Side Setback = 5'
  - Street Side Setback = 15'
  - Rear Setback = 5'
12. Irrigation system to be installed by others. Irrigation system must be protected by either a Pressure Vacuum Breaker, a Reduced Pressure Principle Back Flow Device, or a Double-Check Back Flow Device.
13. All Backflow devices must be installed and tested upon installation.
14. The City shall not be responsible for repairs to parking lot lights or retaining walls that are located in existing utility easements should maintenance/replacement of their associated utilities be deemed necessary.
15. Signage will be permitted separately.
16. **NOTE: Demolition/Construction Waste** - Site is required to provide containment for waste prior to and during demolition/construction. Solid waste roll off boxes and/or metal dumpsters shall be supplied by City or City permitted contractor(s) only.
17. The contractor shall be responsible for the containment and proper disposal of all liquid and solid waste associated with this project. The contractor shall use all means necessary to prevent the occurrence of windblown litter from the project site.
18. Solid waste for the site will continue unaltered.
19. Where electric facilities are installed, BTU has the right to install, operate, relocate, construct, reconstruct, add to, maintain, inspect, patrol, enlarge, repair, remove and replace said facilities upon, over, under, and across the property included in the PUE to access electric facilities.

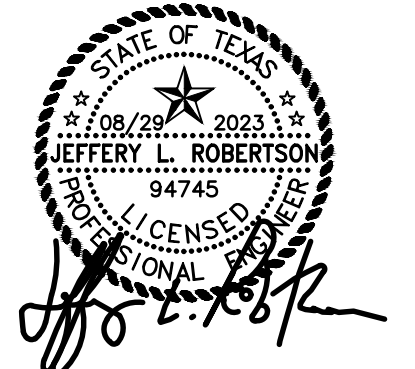

ISSUED FOR BIDDING AND CONSTRUCTION  
2023-09-05 - Revised per SDRC Comments

**SITE PLAN**  
**VILLA MARIA PARKING**

**BRAZOS CHRISTIAN SCHOOL**  
Lot 1R, Block 1 Brazos Christian School Subdivision  
and 0.315 acres of Lot 1, Block 1  
Campbell Estates Subdivision  
being 14.91 Acres Total

BRYAN, BRAZOS COUNTY, TEXAS  
SUBMITTED: MARCH 2023  
SCALE: 1" = 20'

Owner: Brazos Christian School  
3000 W. Villa Maria Rd.  
Bryan, TX 77807  
(979) 823-1000

Prepared By:  
McClure & Browne Engineering/Surveying, Inc.  
1008 Woodcreek Dr., Suite 103  
College Station, Texas 77845  
(979) 693-3838  
Firm Registration No. F-458